

# GV-IPCam H.264

## *Hardware Manual*



- Vandal Proof IP Dome
- Target Vandal Proof IP Dome

Before attempting to connect or operate this product, please read these instructions carefully and save this manual for future use.

ICH264TG2V10



© 2015 GeoVision, Inc. All rights reserved.

Under the copyright laws, this manual may not be copied, in whole or in part, without the written consent of GeoVision.

Every effort has been made to ensure that the information in this manual is accurate. GeoVision, Inc. makes no expressed or implied warranty of any kind and assumes no responsibility for errors or omissions. No liability is assumed for incidental or consequential damages arising from the use of the information or products contained herein. Features and specifications are subject to change without notice. **Note: no memory card slot or local storage function for Argentina.**

GeoVision, Inc.  
9F, No. 246, Sec. 1, Neihu Rd.,  
Neihu District, Taipei, Taiwan  
Tel: +886-2-8797-8377  
Fax: +886-2-8797-8335  
<http://www.geovision.com.tw>

Trademarks used in this manual: *GeoVision*, the *GeoVision* logo and GV series products are trademarks of GeoVision, Inc. *Windows* and *Windows XP* are registered trademarks of Microsoft Corporation.

September 2015

# Content

<b>Content</b> .....	<b>i</b>
<b>Options</b> .....	<b>iii</b>
<b>Note for Adjusting Focus and Zoom</b> .....	<b>v</b>
<b>Note for Installing Camera Outdoor</b> .....	<b>vi</b>
<b>Chapter 1 Vandal Proof IP Dome (Part I)</b> .....	<b>1</b>
1.1 Packing List.....	3
1.2 Features .....	4
1.3 Overview .....	6
1.4 Installation .....	8
1.4.1 Hard-Ceiling Mount .....	9
1.4.2 In-Ceiling Mount.....	15
1.5 Connecting the Camera.....	18
1.5.1 Wire Definition .....	18
1.5.2 Power Connection.....	20
1.5.3 Voltage Load Expansion (Optional).....	21
1.6 Loading Factory Default.....	22
<b>Chapter 2 Vandal Proof IP Dome (Part II)</b> .....	<b>23</b>
2.1 Packing List .....	25
2.2 Features .....	28
2.3 Overview .....	30

2.4	Installation .....	32
2.4.1	Installation of Weatherproof Shield.....	43
2.5	Connecting the Camera.....	45
2.5.1	Power Connection.....	45
2.5.2	I/O Device Connections .....	45
2.6	Loading Factory Default.....	47
<b>Chapter 3 Target Vandal Proof IP Dome.....</b>		<b>48</b>
3.1	Packing List.....	49
3.2	Features .....	52
3.3	Overview .....	54
3.4	Installation .....	56
3.5	Connecting the Camera.....	67
3.6	Loading Factory Default.....	68

## Options

Optional devices can expand your camera's capabilities and versatility. Contact your dealer for more information.

Device	Description
Power Adapter	The power adapter is available for all Vandal Proof IP Dome. Contact your sales representative for the countries and areas supported.
GV-PA191 PoE Adapter	The GV-PA191 PoE adapter is designed to provide power and network connection to the cameras over a single Ethernet cable.
GV-POE Switch	The GV-POE Switch is designed to provide power along with network connection for IP devices. The GV-POE Switch is available in various models with different numbers and types of ports.
GV-Mount Accessories	The GV-Mount Accessories provide a comprehensive lineup of accessories for installation on ceiling, wall corner and pole. For details, see <i>GV-Mount Accessories Installation Guide</i> on the Software DVD.

<b>Device</b>	<b>Description</b>
GV-Relay V2	The GV-Relay V2 is designed to expand the voltage load of GV IP devices. It provides 4 relay outputs, and each can be set as normally open (NO) or normally closed (NC) independently as per your requirement.
Metal PG21 Conduit Connector	The metal PG21 conduit connector is used for running the wires of GV-VD1530 / 2430 / 2530 / 3430, GV-VD1540 / 2440 / 2540 / 3440 / 5340 and GV-VD2540-E / 5340-E and GV-EVD2100 / 3100 through a 3/4" conduit pipe.
Weatherproof Shield	The weatherproof shield is made for GV-VD1530 / 2430 / 2530 / 3430, GV-VD1540 / 2440 / 2540 / 3440 / 5340, and GV-VD2540-E / 5340-E to protect the camera from rain and snow.

## Note for Adjusting Focus and Zoom

When adjusting the Focus and Zoom Screws, do not over tighten the Focus and Zoom screws. The screws only need to be as tight as your finger can do it. It is not necessary to use any tools to get them tighter. Doing so can damage the structure of lens.

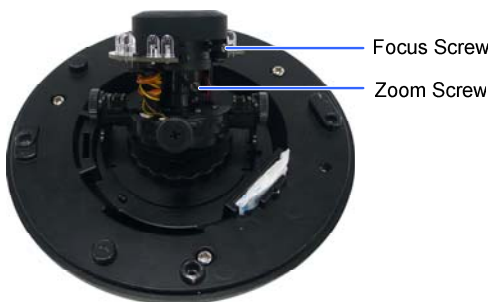

The maximum torque value for all the zoom and focus screws is 0.049 N.m

## Note for Installing Camera Outdoor

When installing the camera outdoor, be sure that:

1. The camera is set up above the junction box to prevent water from entering the camera along the cables.

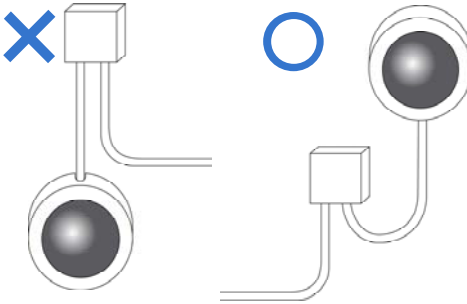

2. Any PoE, power, audio and I/O cables are waterproofed using waterproof silicon rubber or the like.

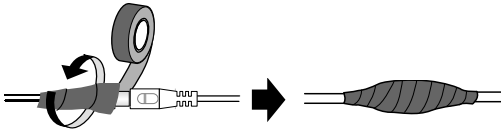



3. After opening the camera cover, ensure the screws are tightened and the cover is in place.



4. The silica gel bag loses its effectiveness when the dry camera is opened. To prevent the lens from fogging up, replace the silica gel bag every time you open the camera, and conceal the gel bag in camera within 2 minutes of exposing to open air.



# Chapter 1 Vandal Proof IP Dome

## (Part I)

The Vandal Proof IP Dome is a series of outdoor camera designed for vandal protection. They are equipped with automatic infrared cut filters and IR LED for day and night surveillance. The **WDR Pro** models can produce clear image for scenes containing contrasting intensity of lights. The **super low lux** models can display color live view in near darkness. For related models, see *1.2 Features*.

These Vandal Proof IP Domes can be installed on wall and ceiling using the standard package. They can also be installed on wall corners and poles using the GV-Mount accessories (optional). For more details, see *GV-Mount Accessories Installation Guide* on the Software DVD.

Model No.		Specification	Description
GV-VD120D (IK10+, Transparent Cover)	Varifocal Lens	Auto Iris, f:3 ~ 9 mm, F/1.3, 1/2.7" ø 14 mm lens mount	1.3 MP Low Lux, H.264, Vandal Proof IP Dome
GV-VD121D (IK10+, Smoked Cover)			
GV-VD122D (IK7, Transparent Cover)			
GV-VD123D (IK7, Smoked Cover)			

Model No.		Specification	Description
GV-VD220D (IK10+, Transparent Cover) GV-VD221D (IK10+, Smoked Cover) GV-VD222D (IK7, Transparent Cover) GV-VD223D (IK7, Smoked Cover)	Varifocal Lens	Auto Iris, f:3 ~ 9 mm, F/1.3, 1/2.7" ø 14 mm lens mount	2 MP, H.264, Vandal Proof IP Dome
GV-VD320D (IK10+, Transparent Cover) GV-VD321D (IK10+, Smoked Cover) GV-VD322D (IK7, Transparent Cover) GV-VD323D (IK7, Smoked Cover)			3 MP, H.264, Vandal Proof IP Dome
GV-VD1500 (IK10+, Transparent Cover) GV-VD2500 (IK10+, Transparent Cover)	Varifocal Lens	Auto Iris, f:3 ~ 9 mm, F/1.2, 1/2.7" ø 14 mm lens mount	1.3 MP / 2 MP Super Low Lux, Vandal Proof IP Dome
GV-VD2400 (IK10+, Transparent Cover)			2 MP / 3 MP, H.264, WDR Pro, Vandal Proof IP Dome
GV-VD3400 (IK10+, Transparent Cover)			

## 1.1 Packing List

- Vandal Proof IP Dome
- Screw Anchor x 4



- Ceiling Screw x 4



- T-Cap Screw x 3



- T-Cap x 3



- Focus Adjustment Cap



- GV-NVR Software DVD

- Warranty Card

- Silica Gel Bag x 2

- Torx Wrench



- Blue Screw x 3



- Small Screw Cap x 3



- Plastic Clip x 3



- 2-Pin Terminal Block

- Power Adapter

- GV-IPCAM H.264 Software DVD

---

### Note:

1. Focus Adjustment Cap is only needed and supplied for IK10+ models.
  2. The power adapter can be excluded upon request.
-

## 1.2 Features

- Image sensor

Camera Model	Image Sensor
GV-VD120D / 121D / 122D / 123D	1/3" progressive scan low lux CMOS
GV-VD1500	1/3" progressive scan super low lux CMOS
GV-VD2500	1/2.8" progressive scan super low lux CMOS
GV-VD2400 / 3400	1/3.2" progressive scan CMOS
GV-VD220D / 221D / 222D / 223D	1/2.5" progressive scan CMOS
GV-VD320D / 321D / 322D / 323D	

- Dual streams from H.264 or MJPEG
- Frame rate

Camera Model	Frame Rate
GV-VD120D / 121D / 122D / 123D / 1500	Up to 30 fps at 1280 x 1024
GV-VD220D / 221D / 222D / 223D / 2400 / 2500	Up to 30 fps at 1920 x 1080
GV-VD320D / 321D / 322D / 323D / 3400	Up to 20 fps at 2048 x 1536

- Day and night function (with removable IR-cut filter)
- Wide Dynamic Range Pro (for GV-VD2400 / 3400 only)
- Defog
- Intelligent IR
- Vandal resistance (IK10+ and IK7)
- Ingress protection (IP67 rating)

- 3-axis mechanism (pan / tilt / roll)
- Micro SD card slot (SD/SDHC) for local storage
- NAS recording
- Recording assigned by GV-Edge Recording Manager (Windows & Mac)
- One sensor input and alarm output
- TV-out support
- Two-way audio
- 3D noise reduction (for GV-VD1500 / 2500)
- 2D noise reduction (except for GV-VD1500 / 2500)
- Motion detection
- Tampering alarm
- Visual automation
- Text overlay
- Privacy mask
- IP address filtering
- DC 12V / AC 24V / PoE (IEEE 802.3af)
- Megapixel lens
- Support for iPhone, iPad, Android and 3GPP
- 31 languages on Web interface
- ONVIF (Profile S) conformant

## 1.3 Overview

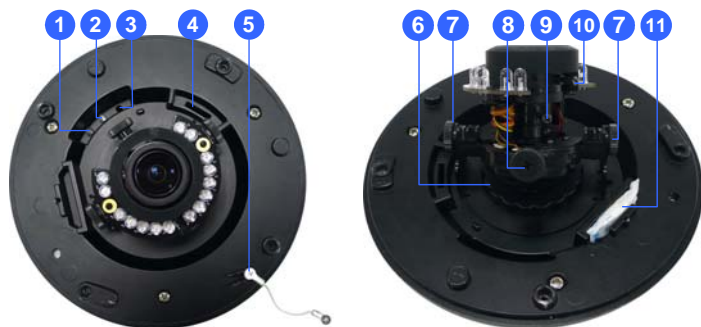

Figure 1-1

No.	Name	Description
1	Power LED	Turns on (green) when the power is on and turns off when there is no power supply.
2	Status LED	Turns on (green) when the system operates normally and turns off when system error occurs.
3	Default Button	Resets the camera to factory default. For details, see <i>1.6 Loading Factory Default</i> .
4	Memory Card Slot	Inserts a micro SD card (SD/SDHC, version 2.0 only, Class 10) to store recording data.
5	Thread Lock	Locks the housing cover to the camera body to prevent the cover from falling.
6	Pan Disc	Loosens to pan the camera.
7	Tilt Screw	Loosen the screw to tilt the camera.



## 1 Vandal Proof IP Dome (Part I)

No.	Name	Description
8	Rotational Screw	Loosens to adjust the camera angle.
9	Zoom Screw	Adjusts the zoom of the camera.
10	Focus Screw	Adjusts the focus of the camera.
11	Silica Gel Bag	Absorbs moisture in the camera body.

## 1.4 Installation

The Vandal Proof IP Dome is designed for outdoors. With the standard package, there are two ways to install the Vandal Proof IP Dome: **hard-ceiling mount** and **in-ceiling mount**.

---

**Note:** You can also install the camera:

- on a power box (of the 4" square and double gang type) using the standard package
- to ceilings, wall corners (concave or convex), and poles using optional mounting kits

For details on these installations, see *GV-Mount Accessories Installation Guide* on the Software DVD.

---

### 1.4.1 Hard-Ceiling Mount



Figure 1-2

1. Unpack the camera package and take out the camera body.

Unscrew the housing cover



Unscrew thread lock



Unscrew the inner housing



Take out the camera body



## 1 Vandal Proof IP Dome (Part I)

2. Mark the position of four screw holes on the desired installation location, and drill holes in the marked locations. Drill the ellipse part if you wish to put the wires through it.



Figure 1-3

3. Insert the screw anchors to the 4 holes on the ceiling.
4. Secure the back cover to the ceiling with 4 ceiling screws.

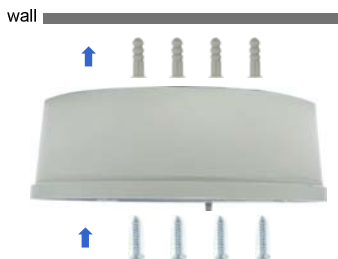

Figure 1-4

5. Refer to step 1 to secure the camera body with inner housing.
6. Thread the cable through the conduit entry at the side of the back cover. Alternatively pass the wires through the ellipse hole at the bottom of the back cover.

7. Connect the network, power and other cables to the camera. See 1.5 *Connecting the Camera*.
8. Access the live view. See 2.1 *Accessing the Live View, GV-IPCam H.264 Firmware Manual*.
9. Based on the live view, adjust the camera to a desired angle as illustrated below.

---

**Tip:** The 3-axis mechanism offers flexible and easy installation.

---

### Pan Adjustment



Figure 1-5

### Tilt Adjustment

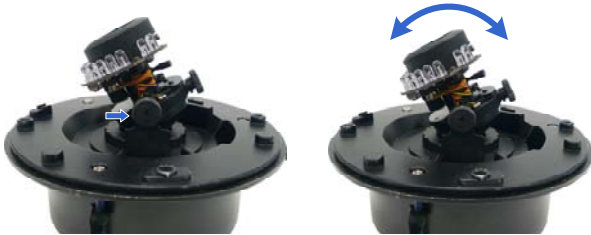

Figure 1-6

### Rotational Adjustment



Figure 1-7

10. Adjust image clarity using the GV-IP Device Utility program. For details, see 2.2 *Adjusting Image Clarity, GV-IPCam H.264 Firmware Manual*.
11. Screw on the thread lock as shown in step 1.
12. Replace the silica gel bag on the camera body within 2 minutes of opening the silica gel bag package.
13. Secure the housing cover to the camera body as shown in step 1.

---

**Note:** Adjust the black mask inside the housing cover to make sure the camera view is not obscured.

---

---

**IMPORTANT:**

1. The gel bag loses its effectiveness when the dry camera is opened. To prevent the lens from fogging up, replace the silica gel bag every time you open the camera and conceal the silica gel bag within 2 minutes of exposing to open air.
  2. Make sure the housing cover is properly secured to prevent water from entering and damaging the inner housing.
-



## 1.4.2 In-Ceiling Mount



Figure 1-8

1. Follow step 1 in *1.4.1 Hard-Ceiling Mount* section to remove the housing cover, thread lock and back cover, and take out the camera body.
2. Cut out a circle with a diameter of 142 mm on the ceiling.
3. Insert a blue screw to the indicated holes on the camera body.



Figure 1-9

4. Screw in a plastic clip to the blue screw, hold it with one hand and use a screw driver to rotate the blue screw until the plastic clip moves half way down.



*Figure 1-10*

5. Secure a T-cap on top of the blue screw with a small screw cap and a T-cap screw. Do not tighten the small screw cap so that the plastic clip can move down freely.

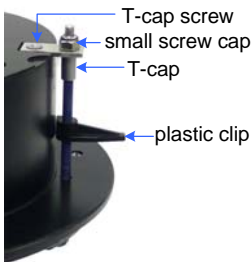

*Figure 1-11*

6. Repeat steps 4 and 5 for the other two blue screws.

7. Insert the camera to the ceiling with the plastic screws moved inward.



*Figure 1-12*

8. Move the blue screws out and rotate the blue screw with a screw driver until the plastic clip and the bottom of the camera body clamps the ceiling tightly.



*Figure 1-13*

9. Connect the network, power and other cables to the camera. See [1.5 Connecting the Camera](#).
10. Access the live view. See [2.1 Accessing the Live View, GV-IPCam H.264 Firmware Manual](#).
11. Follow steps 9 to 10 in [1.4.1 Hard-Ceiling Mount](#) section to adjust the angle, focus and zoom of the camera.
12. Follow steps 11 to 13 in [1.4.1 Hard-Ceiling Mount](#) section to secure the thread lock, replace the silica gel bag and secure the housing cover.

## 1.5 Connecting the Camera

Connect your Vandal Proof IP Dome to power, network and other cables needed.

### 1.5.1 Wire Definition

The cables of Vandal Proof IP Dome are illustrated and defined below.

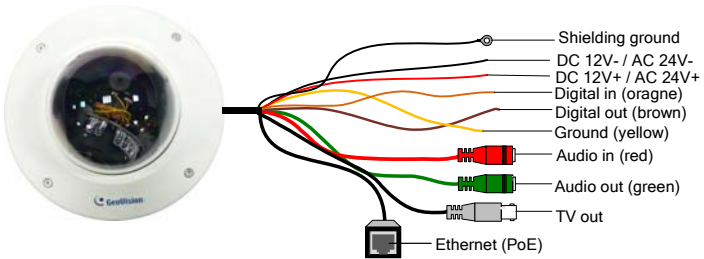

Figure 1-14

No.	Wire Color	Definition
1	Black (thick)	Shielding Ground
2	Black (thin)	DC 12V- / AC 24V-
3	Red	DC 12V+ / AC 24V+
4	Orange	Digital In
5	Brown	Digital out
6	Yellow	Ground
7	Red RCA	Audio in
8	Green RCA	Audio out
9	Black BNC	TV out

---

**Note:** The TV-out function can only be used during installation to adjust the focus of the camera. To use the TV out function, connect the supplied black BNC wire to a monitor and select your signal format (NTSC or PAL) at the **TV Out** field on the Web interface. The default signal format is NTSC. For details, see *4.1.1 Video Settings, GV-IPCam H.264 Firmware Manual*. The TV-out wire must be removed before you secure the housing cover.

---

## 1.5.2 Power Connection

There are two ways to supply power to the camera:

- Use a Power over Ethernet (PoE) adapter to connect the camera to the network, and the power will be provided at the same time.
- Plug the power adapter to the 12V terminal block as shown below.
  1. Insert the thin black wire of the Vandal Proof IP Dome to the left pin (-) and the red wire to the right pin (+).

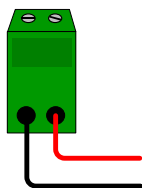

*Figure 1-15*

2. Connect the DC 12V Power Adapter to the Terminal Block.



*Figure 1-16*

### 1.5.3 Voltage Load Expansion (Optional)

The camera can only drive a maximum load of **200mA 5V DC**. To expand the maximum voltage load to **10A 250V AC**, **10A 125V AC** or **5A 100V DC**, connect the camera to a GV-Relay V2 module (optional product). Refer to the figure and table below.

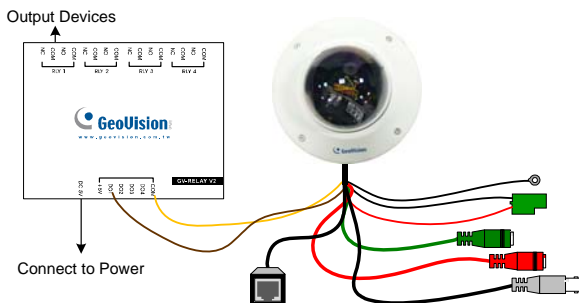

Figure 1-17

GV-Relay V2	Vandal Proof IP Dome
COM	Ground (Yellow)
DO1	Digital Out (Brown)

## 1.6 Loading Factory Default

1. Keep the power and network cables (or PoE) connected to the camera.
2. Use a pin to press and hold the **default** button on the inner housing.
3. Release the **default** button when the **status LED** blinks. This shall take about 8 seconds.
4. When the **status LED** fades, the process of loading default settings is completed and the camera reboots automatically.



Figure 1-18



## Chapter 2 Vandal Proof IP Dome

### (Part II)

This chapter describes the features, physical overview and installation of GV-VD1530 / 2430 / 2530 / 3430, GV-VD1540 / 2440 / 2540 / 3440 / 5340 and GV-VD2540-E / 5340-E.

These Vandal Proof IP Domes are outdoor cameras designed with IK10+ vandal resistance and IP67 ingress protection. They provide superior night vision with their high power LEDs and allow up to 20 m (65.6 ft), 25 m (82 ft) or 30 m (98.4 ft) effective IR distance. The **super low lux** models are able to display color live view in dear darkness. The **WDR Pro** models can process scenes with contrasting intensity of lights. The **motorized varifocal** models support remote focus and zoom adjustment. The **arctic** models can withstand extreme temperatures. For related models, see 2.2 *Features*.

These Vandal Proof IP Domes can be installed on the ceiling using the standard package. They can also be installed on wall surfaces, wall corners and poles using the GV-Mount accessories (optional). For more details, see *GV-Mount Accessories Installation Guide* on the Software DVD.

Model No.		Specification	Description
GV-VD1530 GV-VD2430 GV-VD2530 GV-VD3430	Varifocal lens		1.3 MP Super Low Lux / 2 MP WDR Pro / 2 MP Super Low Lux / 3 MP WDR Pro, H.264, Vandal Proof IP Dome
GV-VD1540 GV-VD2440 GV-VD2540 GV-VD3440	Motorized varifocal lens, high power IR LEDs	Auto Iris, f:3 ~ 9 mm, F/1.2, 1/2.7" ø 14 mm lens mount	1.3 MP Super Low Lux / 2 MP WDR Pro / 2 MP Super Low Lux / 3 MP WDR Pro, H.264, Vandal Proof IP Dome
GV-VD2540-E	Motorized varifocal lens, high power IR LEDs, extreme temperature tolerance		2 MP Super Low Lux, H.264, Vandal Proof IP Dome
GV-VD5340	Motorized Varifocal Lens, high power IR LEDs	Auto Iris, f: 3.3 ~ 9 mm, F/1.2, 1/2.7" ø 14 mm lens mount	5 MP, H.264, Vandal Proof IP Dome
GV-VD5340-E	Motorized varifocal Lens, high power IR LEDs, extreme temperature tolerance		

## 2.1 Packing List

- Vandal Proof IP Dome

- 3-Pin Terminal Block



- Power Adapter



- RJ-45 Connector x 2



- Torx Wrench



- Audio wires



- TV out wire



- Focus Adjustment Cap (for GV-VD1530 / 2430 / 2530 / 3430 only)



- Back Plate



- Installation sticker

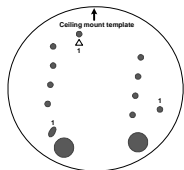

- Screw Anchor x 4



- Long Screw x 4



- Flat Screw



- Short Screw x 2



- Silica Gel Bag x 2

- Sticker (for Silica Gel Bag)

- Ruler

- Conduit Converter

- Plastic PG21 conduit connector



- Power Adepter

- GV-Vandal Proof IP Dome Hardware Installation Guide

- GV-NVR Software DVD

- GV-IPCAM H.264 Software DVD

- Warranty Card

---

**Note:** The power adapter can be excluded upon request.

---

---

**Note:** You can choose to run the wires through a conduit pipe. After you have threaded all the wires, install the supplied conduit converter and plastic PG21 conduit connector with a self-prepared 1/2" conduit pipe to the camera. Power will have to be supplied through a PoE adapter, because the power adapter wire does not fit in a 1/2" pipe. You will have to purchase your own PG21 conduit connector if you want to use 3/4" or 1" pipe.

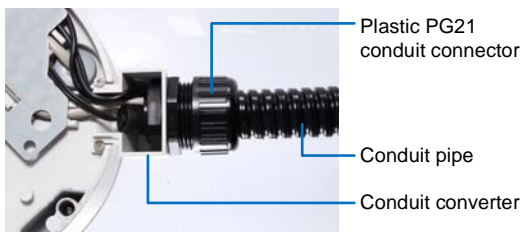

A metal PG21 conduit connector can be purchased upon request. The metal PG21 conduit connector can be connected with a 3/4" pipe.

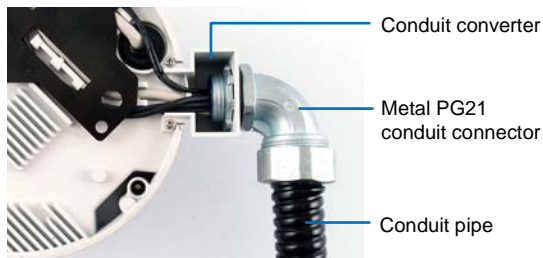

## 2.2 Features

- Image sensor

Camera Model	Image Sensor
GV-VD1530 / 1540	1/3" progressive scan super low lux CMOS
GV-VD2430 / 2440 GV-VD3430 / 3440	1/3.2" progressive scan CMOS
GV-VD2530 / 2540 GV-VD2540-E	1/2.8" progressive scan super low lux CMOS
GV-VD5340 GV-VD5340-E	1/2.5" progressive scan CMOS

- Minimum illumination at 0.01 lux (GV-VD1530 / 1540 / 1540-E)
- Dual streams from H.264 or MJPEG
- Frame rate

Camera Model	Frame Rate
GV-VD1530 / 1540	Up to 30 fps at 1280 x 1024
GV-VD2430 / 2440 GV-VD2530 / 2540 GV-VD2540-E	Up to 30 fps at 1920 x 1080
GV-VD3430 / 3440	Up to 20 fps at 2048 x 1536
GV-VD5340 GV-VD5340-E	Up to 10 fps at 2560 x 1920

- Day and night function (with removable IR-cut filter)
- Intelligent IR
- External high-power IR LEDs
- Wide Dynamic Range Pro (for GV-VD2430 / 2440 / 2440-E / 3430 / 3440 / 3440-E)
- Motorized varifocal lens for remote focus/zoom adjustment (GV-VD1540 / 1540-E / 2440 / 2440-E / 2540 / 2540-E / 3440 / 3440-E / 5340 / 5340-E)
- Defog
- Vandal resistance (IK10+)

- Ingress protection (IP67 rating)
- Wide temperature tolerance: -40°C ~ 50°C / -40°F ~ 122°F  
(for GV-VD2540-E / 5340-E)
- 3-axis mechanism (pan / tilt / roll)
- Micro SD card slot (SD/SDHC) for local storage
- NAS recording
- Recording assigned by GV-Edge Recording Manager (Windows & Mac)
- One sensor input and alarm output
- TV-out support
- Two-way audio
- 3D noise reduction (for GV-VD1530 / 1540 / 2530 / 2540 / 2540-E)
- 2D noise reduction (for GV-VD2430 / 2440 / 3430 / 3440 / 5340 / 5340-E)
- Motion detection
- Tampering alarm
- Visual automation
- Text overlay
- Privacy mask
- IP address filtering
- DC 12V / AC 24V / PoE+ (IEEE 802.3at)
- Megapixel lens
- Support for iPhone, iPad, Android and 3GPP
- 31 languages on Web interface
- ONVIF (Profile S) conformant

## 2.3 Overview



Figure 2-1



No.	Name	Description
1	LED Indicators	The power LED (top) turns on (green) when the power is on and turns off when there is no power supply. The status LED (bottom) turns on (green) when the system operates normally and turns off when system error occurs.
2	Audio In	Connects to a microphone for audio output.
3	LAN / PoE	Connects to a 10/100 Ethernet or PoE.
4	Default Button	Resets the camera to factory default. For details, see <i>2.6 Loading Factory Default</i> .
5	Video Out	Connects to a portable monitor for setting the focus and angle of the camera during initial setup.
6	Memory Card Slot	Inserts a micro SD card (SD/SDHC, version 2.0 only, Class 10) to store recording data.
7	Audio Out	Connects to a speaker for audio output.
8	DC 12V / AC 24V	Connects to power.
9	I/O Terminal Block	Connects to an I/O device.
10	Rotational Screw	Loosens to rotate the camera.
11	Cable seal	Waterproofs the Ethernet cable.
12	Tilt Screw	Loosen the screw to tilt the camera.
13	Conduit Connector	Waterproofs the audio, TV out, power adapter and I/O wires.
14	Silica Gel Bag	Absorbs moisture in the camera body.

## 2.4 Installation

The Vandal Proof IP Dome is designed for outdoors. With the standard package, you can install the camera on the ceiling.

---

**Note:** You can also install the camera:

- on a power box (of the 4" square and double gang type) using the standard package
- to ceilings, wall corners (concave or convex), and poles using optional mounting kits

For details on these installations, see *GV-Mount Accessories Installation Guide* on the Software DVD.

---

**IMPORTANT:** When installing the Vandal Proof IP Dome near the corner, maintain at least 25 cm away from the walls to avoid reflection problems.

---

1. Remove the housing cover with the supplied torx wrench.
2. Thread wires into the camera.
  - A. Unscrew the conduit connector from the back.

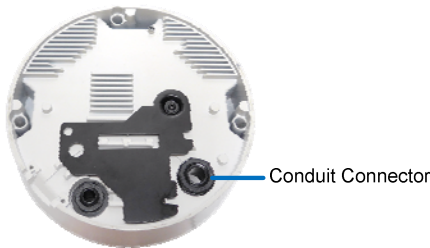

Figure 2-2

- B. Unplug the conduit connector inside the housing and disintegrate the connector. You should have 4 parts:



Figure 2-3

- C. Remove the terminal block from the supplied power adapter.  
D. Thread the audio wires (optional), TV out wire (optional), adapter wires and I/O wires (optional) through the conduit entry and then through part 1, 2, 3 and 4 of the conduit connector.

---

### Tip:

1. To make the threading easier, it is advised to thread the wires in the order described here.
  2. Use a pair of pliers to help you pull the wires through the camera.
- 

For part 2, there are 8 holes each labeled with its diameter. Remove the plugs and push the wires to the corresponding hole listed below:

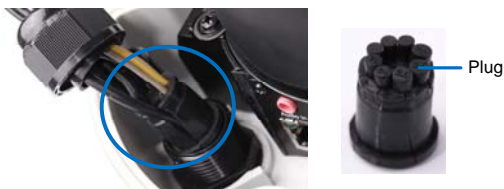
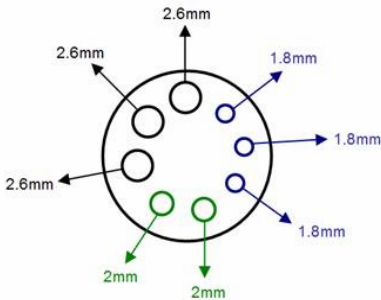

Figure 2-4



2.6 mm: Audio, BNC

2 mm: DC12V / AC24V

1.8 mm: DIDO

Figure 2-5

---

**IMPORTANT:**

1. Use the supplied ruler and leave about 10 cm of power and I/O wires between their connectors and the cable seal; leave at least 11 cm of audio/TV-out wires between their connectors and the cable seal.
  2. The plugs are used to prevent water from entering the camera housing. Keep the unused holes plugged and save the removed plugs for future use.
  3. Only thread the wires through their designated holes on the conduit connector to make sure the wires are properly sealed.
-

3. Install the Ethernet cable.

A. Rotate to remove the indicated cap and the plug inside.



Figure 2-6

B. Thread an Ethernet cable (the end with no RJ-45 connector) from the back panel through the cable seal



Figure 2-7

---

**IMPORTANT:** Use the supplied ruler and leave about 11 cm of the Ethernet cable between the connector and the cable seal.

---

C. Re-install the cap. Make sure the cap is installed tightly to waterproof the camera.

4. Connect the wires to the camera.
  - A. Install the terminal blocks to the power adapter and I/O devices.  
See 2.5.1 *Power Connection* and 2.5.2 *I/O Device Connections*.
  - B. Install the supplied RJ-45 connector to the Ethernet cable.
  - C. Plug all the connectors to the camera panel.

---

**Tip:** Unscrew the indicated screws and lift the camera to help you connect the wires.

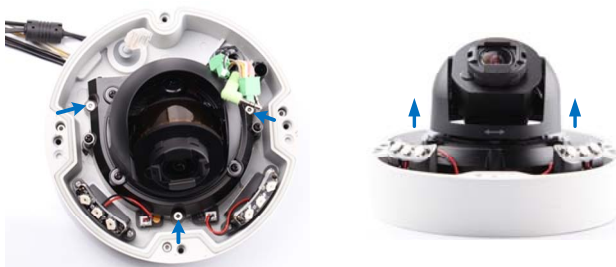

- D. Arrange the wires in the conduit connector and re-install it to the camera.

- Sort out the wires at the back. You can have the wires come out from position A, B or both. The instructions here describe sorting wires for position A.

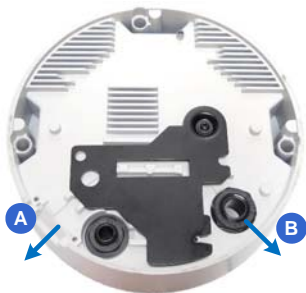

Figure 2-8

From the back of the camera housing, unscrew and rotate the plate to one side, sort out the wires and secure the plate back.

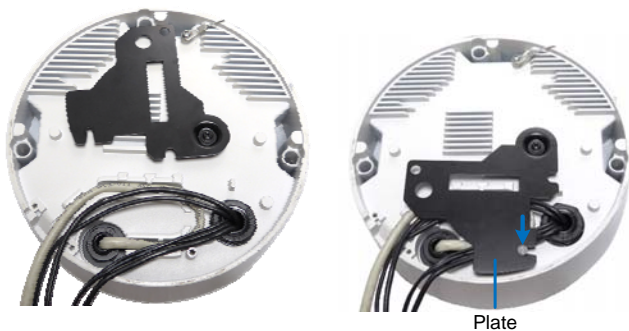
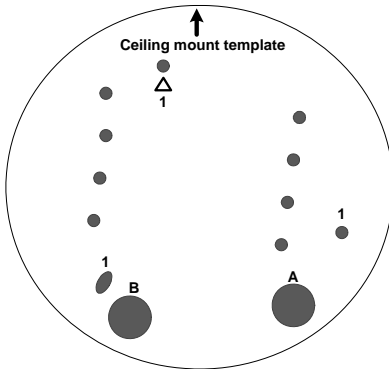

Figure 2-9

6. Secure the back plate to the ceiling.
  - A. Paste the sticker to the ceiling. The arrow on the sticker indicates the direction that the camera faces.



*Figure 2-10*

- B. Drill 3 holes for screws. The recommended ones are indicated as '1'.
- C. Insert the screw anchors to the 3 holes.
- D. Depending on how you want to run the wires (see step 5). Drill the right hole (Figure 2-10) for position A and the left for position B or both if required.
- E. Secure the back plate to the ceiling with long screws.



7. Secure the camera to the ceiling.
  - A. Secure the safety lock to the camera using a short screw. Use flat screw for number 1 and small screw for number 2.



Figure 2-11

- B. Thread all the wires into the ceiling and connect them.

---

**Note:** The TV-out function can only be used during installation to adjust the focus of the camera. To use the TV out function, connect the supplied black BNC wire to a monitor and select your signal format (NTSC or PAL) at the **TV Out** field on the Web interface. The default signal format is NTSC. For details, see [4.1.1 Video Settings, GV-IPCam H.264 Firmware Manual](#). The TV-out wire must be removed before you secure the housing cover.

---

- C. Secure the camera using the torx wrench

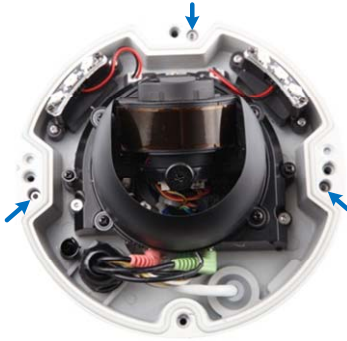

*Figure 2-12*

8. Access the live view. See *2.1 Accessing the Live View, GV-IPCam H.264 Firmware Manual*.
9. Adjust the camera's angle, focus and zoom of the camera.

#### **Pan Adjustment**



*Figure 2-13*

### Tilt Adjustment



Figure 2-14

### Rotational Adjustment



Figure 2-15

10. Replace the silica gel bag and secure the camera cover using the torx wrench.

---

**IMPORTANT:**

1. The gel bag loses its effectiveness when the dry camera is opened. To prevent the lens from fogging up, replace the silica gel bag every time you open the camera and conceal the silica gel bag within 2 minutes of exposing to open air.
2. Make sure the housing cover is properly secured to prevent water from entering and damaging the inner housing.
3. If the center of the camera view is less than  $25^\circ$  to the ceiling, or lower than the grey line (as illustrated below), disassemble the indicated ring so the view is not obstructed. However, with the ring disassembled, slight reflections may occur.



## 2.4.1 Installation of Weatherproof Shield

Optionally purchase a weatherproof shield to protect the camera from rain and snow.



Figure 2-16

---

**Note:** A weatherproof shield can be purchased upon request. The pan and tilt angle of the camera is limited by the shield.

---

1. Remove the housing cover.



Figure 2-17

2. Remove the three screws from the housing cover.



*Figure 2-18*

3. Secure the three screws of the weatherproof shield to the housing cover.

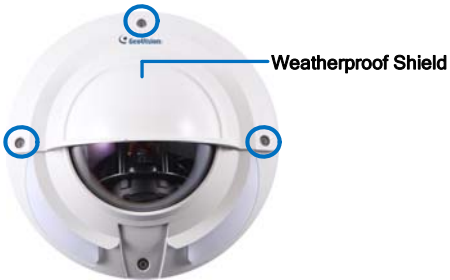

*Figure 2-19*

4. Secure the housing cover.

## 2.5 Connecting the Camera

Connect your Vandal Proof IP Dome to power, network and other wires needed.

### 2.5.1 Power Connection

There are two ways to supply power to the camera:

- Use a Power over Ethernet (PoE) adapter to connect the camera to the network, and the power will be provided at the same time.
- Plug the power adapter to the terminal block by inserting the striped wire to the right pin (-) and the black wire to the left pin (+).



Figure 2-20

### 2.5.2 I/O Device Connections

The camera supports one digital input and one digital output of dry contact.

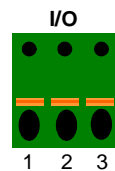

Figure 2-21

Pin	Function
1	Digital Output
2	GND
3	Digital Input

For details on how to enable an installed I/O device, see [4.2 I/O Settings](#), *GV-IPCam H.264 Firmware Manual*.

### 2.5.3 Voltage Load Expansion (Optional)

The camera can only drive a maximum load of **200mA 5V DC**. To expand the maximum voltage load to **10A 250V AC**, **10A 125V AC** or **5A 100V DC**, connect the camera to a GV-Relay V2 module (optional product). Refer to the figure and table below.

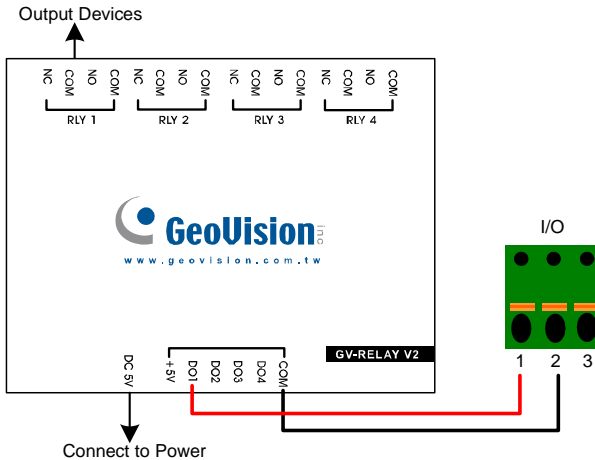

Figure 2-22

GV-Relay V2	Vandal Proof IP Dome
COM	Pin 2 of I/O terminal block
DO1	Pin 1 of I/O terminal block



## 2.6 Loading Factory Default

1. Keep the power and network cables (or PoE) connected to the camera.
2. Use a pin to press and hold the **default** button on the inner housing.
3. Release the **default** button when the **status LED** blinks. This shall take about 8 seconds.
4. When the **status LED** fades, the process of loading default settings is completed and the camera reboots automatically.

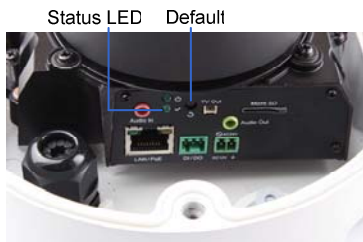

Figure 2-23

## Chapter 3 Target Vandal Proof IP Dome

The Target Vandal Proof IP Dome is an outdoor camera designed with IK10 vandal resistance and IP67 ingress protection. The camera is equipped with an automatic IR-cut filter and IR LEDs for day and night surveillance. With the super low lux CMOS image sensor, the camera is capable of providing a color live view in near darkness. Adjustable in 3 axis (pan, tilt and rotate), it offers an entry-level surveillance solution with all the essential features and excellent image quality.

Model No.		Specifications	Description
GV-EVD2100	Varifocal lens	Auto Iris, f:3 ~ 9 mm, F/1.7, 1/2.8" ø 14 mm lens mount	2 MP H.264, WDR, Super Low Lux
GV-EVD3100			3 MP H.264, WDR Pro, Super Low Lux

### 3.1 Packing List

- Target Vandal Proof IP Dome

- Screw x 4



- TV-Out Wire



- Installation sticker

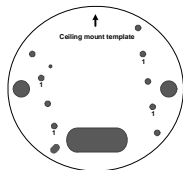

- Conduit Converter



- Torx Wrench



- Screw Anchor x 4



- Audio Wires x 2





- RJ-45 Connector



- Water proof rubber set (for RJ-45 and DC12V)



- Big Concave hexagon Wrench  

- Small Concave hexagon Wrench  

- Silica Gel Bag
- Sticker (for Silica Gel Bag)
- GV-IPCAM H.264 Software DVD
- Ruler
- GV-NVR Software DVD
- Warranty Card

---

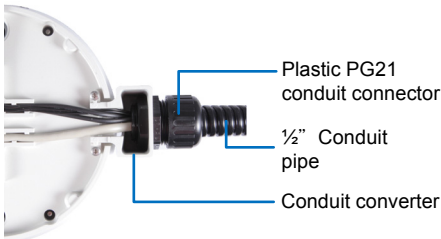
**Note:**

1. Power adapter can be purchased upon request.
2. With the supplied Conduit Converter, you can choose to run the wires through a conduit pipe. The installation of conduit converter and conduit pipe is illustrated as below. You may optionally purchase a plastic or metal PG21 conduit connector for a 1/2" or 3/4" pipe respectively. When you use a 1/2" pipe, power will have to be supplied through a PoE adapter because the power adapter wire does not fit in a 1/2" pipe.



### 3 Target Vandal Proof IP Dome

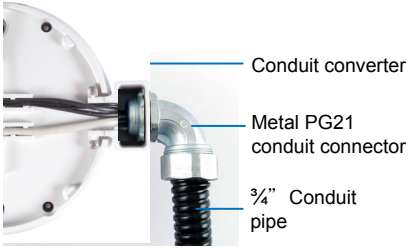

## 3.2 Features

- 1/2.8" progressive scan super low lux CMOS
- Min. illumination

Camera Model	Min. Illumination
GV-EVD2100	0.004 lux
GV-EVD3100	0.01 lux

- Dual streams from H.264 and MJPEG
- Frame Rate

Camera Model	Frame Rate
GV-EVD2100	Up to 30 fps at 1920 x 1080
GV-EVD3100	Up to 30 fps at 2048 x 1536

- Vandal resistance (IK10 for metal casing)
- Ingress protection (IP67)
- Megapixel lens
- P-iris lens for auto iris control
- Intelligent IR
- IR distance up to 50 m (164 ft)
- Day and Night function (with removable IR-cut filter)
- 3-axis mechanism (pan / tilt / rotate)
- DC 12V / PoE (IEEE 802.3af)
- Two-way audio
- Wide Dynamic Range (WDR) for GV-EVD2100
- Wide Dynamic Range Pro (WDR Pro) for GV-EVD3100
- Defog
- Motion detection
- Tampering alarm

- Text overlay
- Privacy mask
- IP address filtering
- NAS recording
- Recording assigned by GV-Edge Recording Manager (Windows & Mac)
- Supports iPhone, iPad, Android & 3GPP
- 31 languages on Web interface
- ONVIF (Profile S) conformant

---

**Note:** For optimal performance and compatibility, it is highly recommended to use a GV-NAS System.

---

### 3.3 Overview

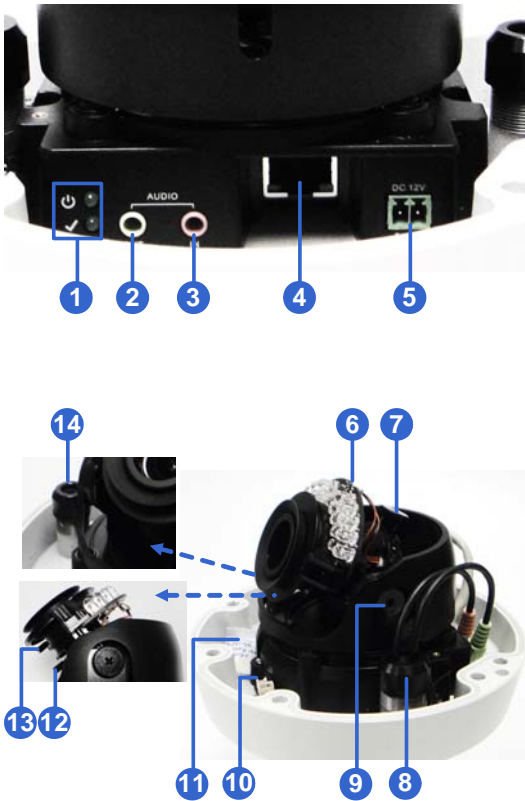

Figure 3-1



No.	Name	Description
1	LED Indicators	The power LED (top) turns on (green) when the power is on and turns off when there is no power supply. The status LED (bottom) turns on (green) when the system operates normally and turns off when system error occurs.
2	Audio Out	Connects to a speaker for audio output.
3	Audio In	Connects to a microphone for audio input.
4	LAN / PoE	Connects to a 10/100 Ethernet or PoE.
5	DC 12V	Connects to power.
6	Default Button	Resets the camera to factory default. For details, see <i>3.6 Loading Factory Default</i> .
7	Rotational Screw	Loosens to rotate the camera.
8	Cable seal	Waterproofs the Ethernet cable.
9	Tilt Screw	Loosens the screw to tilt the camera.
10	TV-Out	Provides video input (D1 resolution) for a monitor.
11	Silica Gel Bag	Absorbs moisture in the camera body.
12	Zoom Screw	Adjusts the zoom of the camera.
13	Focus Screw	Adjusts the focus of the camera.
14	Conduit Connector	Waterproofs the audio wires.

---

**Note:** The TV-out function can only be used during installation to adjust the focus of the camera. To use the TV out function, connect the supplied black BNC wire to a monitor and select your signal format (NTSC or PAL) at the **TV Out** field on the Web interface. The default signal format is NTSC. For details, see *4.1.1 Video Settings, GV-IPCam H.264 Firmware Manual*. The TV-out wire must be removed before you secure the housing cover.

---

## 3.4 Installation

The Target Vandal Proof IP Dome is designed for outdoors. With the standard package, you can install the camera on the ceiling.

---

**Note:** You can also install the camera to ceilings, wall corners (concave or convex), and poles using optional mounting kits.

For details on these installations, see *GV-Mount Accessories Installation Guide* on the Software DVD.

---

1. Remove the housing cover with the supplied torx wrench.



*Figure 3-2*

2. Remove the back plate with the supplied torx wrench and remove the safety lock with a Philips screwdriver. Keep the removed screw for later use.



Figure 3-3

3. Thread an Ethernet cable and/or the adapter wire into the camera.
  - A. Rotate to remove the indicated cap.



Figure 3-4

- B. Take out and disintegrate the connector. You should have 3 parts:



Figure 3-5

- C. Thread an Ethernet cable (the end without RJ-45 connector) and/or the adapter wire from the back panel.



Figure 3-6

- D. If you are using PoE, thread an Ethernet cable through part 1 of the connector.
- E. If you are using DC 12V, change the connector to the supplied waterproof rubber set. Remove the terminal block from the power adapter and thread the adapter wire through the rubber.

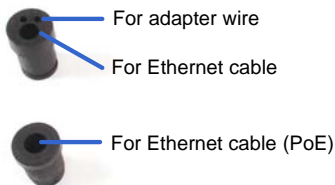

Figure 3-7

- F. Thread the Ethernet cable and/or the adapter wire through part 2 and 3 of the connector.



Figure 3-8

---

**IMPORTANT:** Use the supplied ruler and leave about 14 cm of the Ethernet cable and 10 cm of the adapter wire between the connector and the cable seal.

---

- G. Re-install the cap (part 3) with the supplied big concave hexagon wrench. Make sure the cap is installed tightly to waterproof the camera.
4. Thread audio wires (optional) into the camera.
- A. Rotate to remove the cap of the conduit connector.



Figure 3-9

- B. Take out and disintegrate the connector. You should have 3 parts too.

- C. Thread the audio wires from the back panel, remove the plugs of part 1 and thread through the 3 parts of the connector.



Figure 3-10

- D. Re-install the cap (part 3) with the supplied small concave hexagon wrench. Make sure the cap is installed tightly to waterproof the camera.

---

**Tip:** Use a pair of pliers to help you pull the wires through the camera.

---

---

**IMPORTANT:**

1. Use the supplied ruler and leave about 10 cm of the audio wires between the connectors and the cable seal.
  2. The plugs are used to prevent water from entering the camera housing. Keep the unused holes plugged and save the removed plugs for future use.
-

5. Connect the wires to the camera.
  - A. Install the terminal block to the power adapter. See 3.5 *Connection the camera*.
  - B. Install the supplied RJ-45 connector to the Ethernet cable.
  - C. Plug all the connectors to the camera panel.

---

**Tip:** Unscrew the indicated screws and lift the camera to help you connect the wires.



6. Sort out the wires at the back. You can have the wires come out from both positions A and B, or from C.

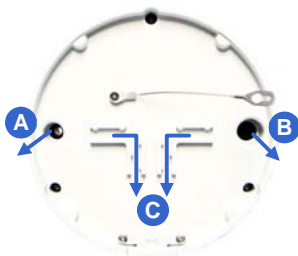
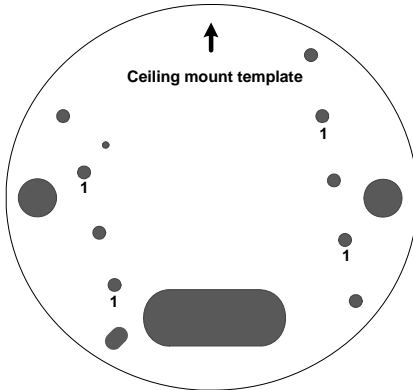

Figure 3-11

7. Secure the back plate to the ceiling.
  - A. Paste the sticker to the ceiling. The arrow on the sticker indicates the direction that the camera faces.



*Figure 3-12*

- B. Drill 4 holes for screws. The recommended ones are indicated as '1'.
- C. Insert the screw anchors to the 4 holes.
- D. Drill A & B holes or only C hole for sorting out the wires according to Figure 5-11.
- E. Secure the back plate to the ceiling with the supplied screws.



8. Secure the camera to the ceiling.
  - A. Secure the safety lock to the camera with the screw you removed from the back plate in step 2.



Figure 3-13

- B. Thread all the wires into the ceiling and connect them.
  - C. Secure the camera with the torx wrench.



Figure 3-14

9. Access the live view. See *2.1 Accessing the Live View, GV-IPCam H.264 Firmware Manual*.

---

**Note:** The TV-out function can only be used during installation to adjust the focus of the camera. To use the TV out function, connect the supplied black BNC wire to a monitor and select your signal format (NTSC or PAL) at the **TV Out** field on the Web interface. The default signal format is NTSC. For details, see *4.1.1 Video Settings, GV-IPCam H.264 Firmware Manual*. The TV-out wire must be removed before you secure the housing cover.

---

10. Adjust the camera's angle, focus and zoom of the camera.

#### **Pan Adjustment**



*Figure 3-15*

### Tilt Adjustment



Figure 3-16

### Rotational Adjustment



Figure 3-17

11. Replace the silica gel bag, press all the wires and cables into the notch and secure the camera cover with the torx wrench.



*Figure 3-18*

---

**IMPORTANT:**

1. The gel bag loses its effectiveness when the dry camera is opened. To prevent the lens from fogging up, replace the silica gel bag every time you open the camera and conceal the silica gel bag within 2 minutes of exposing to open air.
  2. Make sure the housing cover is properly secured to prevent water from entering and damaging the inner housing.
-

### 3.5 Connecting the Camera

There are two ways to supply power to the camera:

- Use a Power over Ethernet (PoE) adapter to connect the camera to the network, and the power will be provided at the same time.
- Plug the power adapter to the terminal block by inserting the striped wire to the right pin (-) and the black wire to the left pin (+).



Figure 3-19

## 3.6 Loading Factory Default

1. Keep the power and network cables (or PoE) connected to the camera.
2. Press and hold the **default** button for about 8 seconds.
3. Release the **default** button when the **status LED** blinks.
4. When the **status LED** fades, the process of loading default settings is completed and the camera reboots automatically.

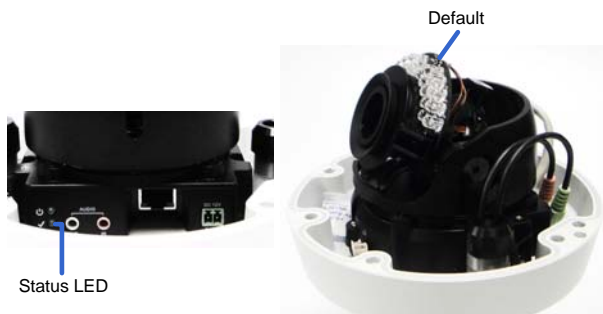

Figure 3-20